



NightWatcher

NW-4MP-BP-WH

NW-8MP-BP-WH

PIR Bullet Cameras

Quick start guide

Table of Contents

Introduction.....	2
CCTV and the law.....	3
1. Camera description.....	4
2. Detection range.....	5
3. Camera installation.....	6
4. Adjusting camera settings.....	8
5. PIR local settings.....	9
6. Maintenance.....	10
7. Support.....	11
8. Product compliance.....	11
9. Specifications.....	11

Introduction

This series HDCVI camera conforms to the HDCVI standard. It supports video signal high-speed, long distance transmission without any delay. It can be controlled by the HCVR conforming to the HDCVI.

Features

- Adopts high performance CMOS image sensor, megapixel definition.
- Supports coaxial transmission of HD video and control signal.
- For 720P series, supports 75-3 coaxial cable transmission without any loss. The distance is up to 500m. For 1080P, 4M series, supports 75-3 coaxial cable transmission without any loss. The distance is over 300m.
- High speed, long distance real-time transmission.
- Supports OSD menu adjusting parameters.
- Supports DC 12V power supply.
- Adopts quaternionic digital sensor, efficiently improve detection accuracy.
- Digital temperature compensation technology, adapt to environmental change.
- Detection distance: 10m, detection angle: 110° .
- Supports IP67 compliance.

Important Safeguards and Warnings

1 . Electrical safety

- This device runs on 12V DC, so installing this device is very safe. It should not require any specialist electrical expertise. However, please use common sense and take care not to disturb any existing mains electrical wires during installation. Please follow local electrical safety regulations with regard to this installation and existing systems. Consult with a qualified electrician if you have any doubts about safety.
- Only use this device with the power supply provided.
- The power supply provided will work perfectly with the power lines provided. However, beware of extending the power lines over 100m, as this may affect voltage at the camera and long cable runs increase the risk of signal interference. If you need to extend the lines beyond what is supplied call NightWatcher support for further advice.
- Please install the wires and mains adapter such that they will not be trampled, crushed, stretched or subjected to temperatures over 50 °C.
- Ensure good ventilation around the mains adapter and never cover it, so that it does not overheat.

2 . Environment

- Please don't aim the camera at strong light sources (such as security lights, sunlight, strong reflected sunlight etc.) as this may damage the CMOS sensor.
- This camera is highly weather resistant (IP67). However, when siting the camera try to avoid areas where water will constantly drip onto it (from leaking gutters etc.)
- This camera is highly resistant to sunlight, but when siting the camera avoid areas of very strong direct sunlight if possible.

- When siting the camera try to provide adequate ventilation to avoid accumulation of heat (e.g. roof spaces).
- When siting the camera consider what objects in view will trigger the camera to give frequent false 'alarms', such as bushes, trees, vehicles moving past in the road etc.
- Heavy stress, violent vibration or water splash are not allowed during transportation, storage and installation.
- Please pack the device with standard factory packaging or material with same quality when transporting the device.
- It is recommended to use the device together with lightning protection device to enhance lightning protection effect.
- It is recommended to earth (GND) the device to enhance device reliability.
- It is advised to use qualified video transmission cable to improve video quality. It is recommended to use RG59 coaxial cable or higher standard.

CCTV and the law

CCTV systems are subject to specific legislative restrictions in the EU/UK. You are allowed to operate CCTV systems on your own property to protect that property, but you must preserve the privacy of your neighbours and the general public.

- Do not point cameras at neighbour's windows,
- Avoid covering areas that are not your property in camera view where possible
- Do not keep recordings for longer than is necessary for security purposes
- Do not publish or display video footage out of context of security.
- Do display a 'CCTV in operation' sign within the area of your surveillance.

To avoid conflict with your neighbours, you should discuss the siting and angle of cameras with them before you install. For further details of the law on CCTV, look at our website www.nightwatcher.co.uk or directly at government websites with reference to the following legislation.

- The Protection of Freedoms Act 2012
- The Surveillance Camera Code of Practice 2013 (the 'SCOOP')
- The Data Protection Act (the 'DPA')

Warning

- Please use the standard accessories provided by manufacturer.

Help is always at hand!

If you have any doubts or problems with your product, contact NightWatcher support for FAQs, help and advice. www.nightwatcher.co.uk

What's in the box

1. Camera
2. 3 self-tapping screws
3. 3 plastic raw plugs

1 Camera description

All measurements in mm (inch).

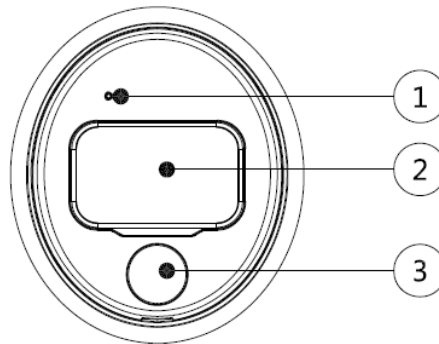
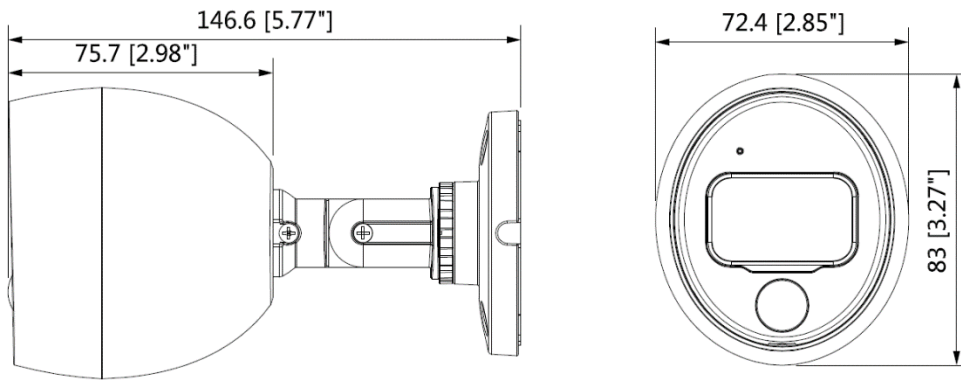

Number	Part name
1	Alarm indicator light
2	Lens
3	PIR lens

DC in cable

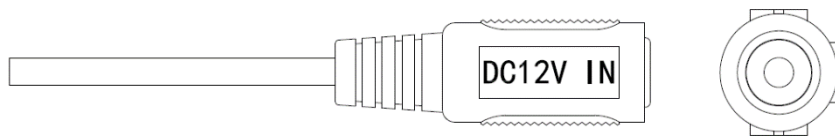

Video output cable

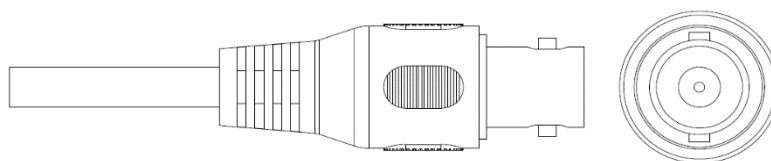

2 Detection Range

The horizontal sensing range of the PIR detector is shown below. The horizontal sensing angle is 110° .

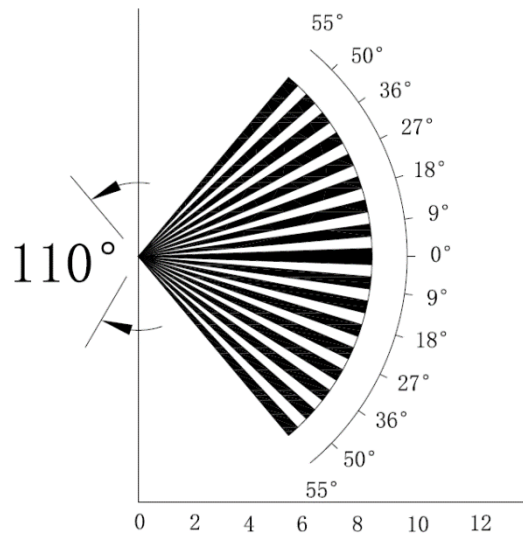

The vertical sensing distance of the detector is shown below. The sensing range min = 2m max = 10m . The bracket supports 3-axis adjustment.

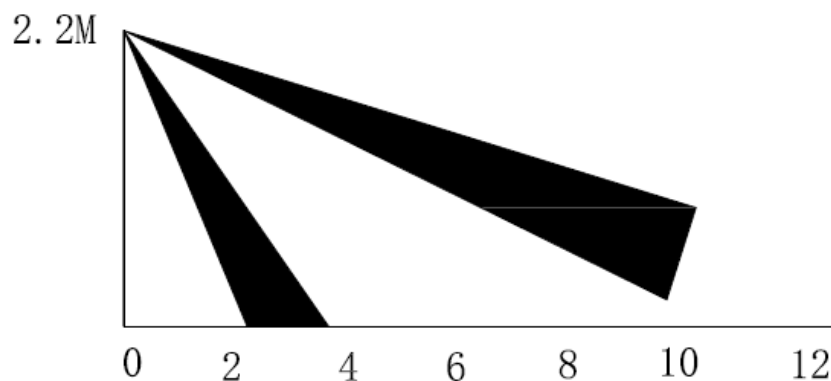

Note:

Set the detector angle to trigger the camera when intruders enter the area. Try to set this angle to exclude frequent non-intruder events, such as passing cars, moving bushes etc. The range of the PIR is limited, far shorter than the range on 'motion detect'. This can be used to eliminate false triggering.

Note ; Maximum range

Note that as the PIR/camera angle to the horizontal increases, (becomes more vertical) the range of the PIR is reduced as the field of view is wider than it is deep. Maximum range can only be achieved with the camera/PIR completely horizontal or more precisely 0-15 degrees from horizontal.

3 Camera Installation

Caution

- The installation ceiling or wall must be thick enough to sustain at least 3x weight of the camera.
- Avoid siting the camera in locations exposed to extreme weather, very strong sunlight, driving rain, howling gales etc.
- Do not install the camera in a location with extremely high temperature.
- Bear in mind that PIR detectors sense rapid changes in heat. Anything in view that changes temperature quickly may trigger the sensor (e.g. boiler exhaust vents and exhaust plumes, strong reflected sunlight).
- Please do not remove the electrostatic adsorption film on the surface of transparent cover before installation is completed, to avoid damage during handling/installation;
- The following installation figure is for reference only.

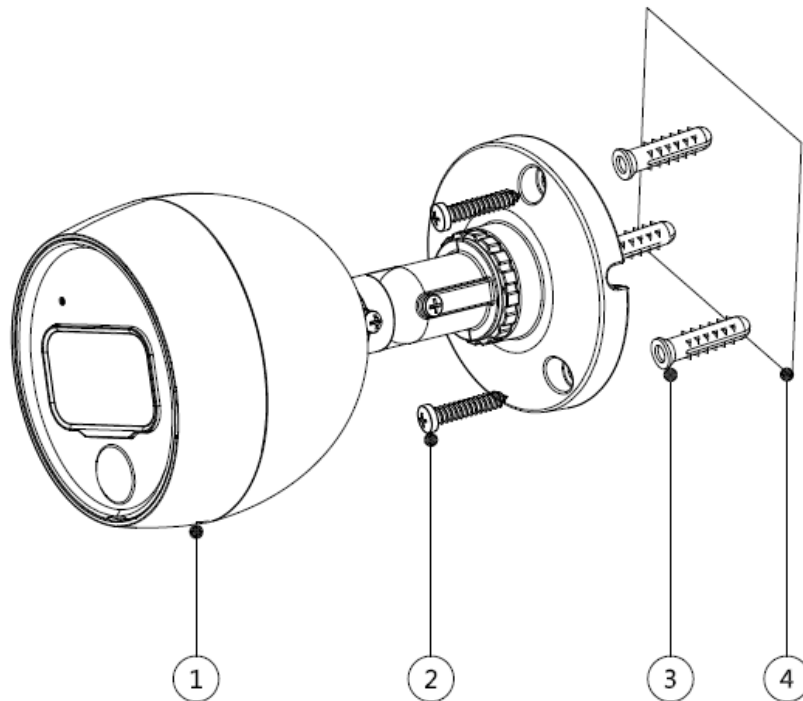

SN	Name
1	Camera Body
2	Self-tapping Screw
3	Raw-plug
4	Installation Surface

Step 1

Install camera bracket.

- The mounting bracket /camera pedestal at the base of the camera can be unscrewed from the camera. You may find this useful during installation. If you do unscrew this bracket, remember to thread the cable back through it before tightening the screws
- If installing on a brick, concrete or other masonry surface you should drill holes for raw plugs then install bracket and screw through the bracket holes into the raw plugged holes (as shown above).
- If mounting onto a wooden surface, do not use raw plugs. Screw the bracket directly to the wooden surface with the self-tapping screw.
- If mounting to stud-wall or similar surface you will need to use specialized expansion plugs for that surface. These are not provided in this kit but are available at all good DIY centres.
- Mounting to false ceilings, ceiling tiles etc. also requires additional materials not provided in this kit. Typically, you would need to use a wooden backing board above the ceiling tile to bolster the ceiling tile and provide a strong surface to support the screws. For this you would need longer screws than those provided but of the same diameter.

Step 2

Install camera ①. If you separated the screw mounting bracket, you will need to thread the cable back through the bracket and screw the camera back into the bracket. Take care not to twist or damage the cable.

Step 3

Adjust the camera to the desired monitoring angle, and then tighten the rotating button on the bracket to fix the camera.

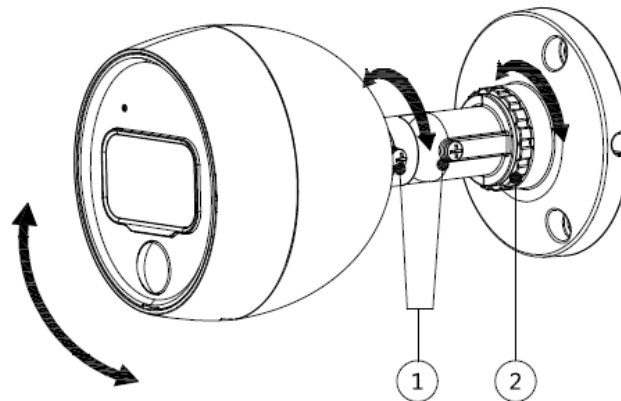

SN	Name
1	Bracket Adjusting Screw
2	Bracket Adjusting Ring

Step 4

Connect the camera video output port to the HDCVI DVR and connect the power port to power. Physical camera installation is now complete! Now switch on the DVR to check monitoring image.

4 Adjusting the camera settings

Cross-refer with your DVR instructions as they will be specific to the DVR.

Now use the mouse connected to the DVR to navigate the onscreen menus on your TV.

In the live view screen interface, right-click anywhere on the screen.

The shortcut menu is displayed.

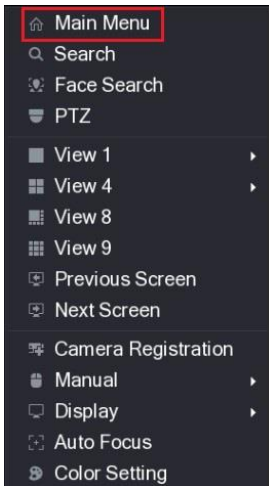

Click Main menu>Camera>Encode

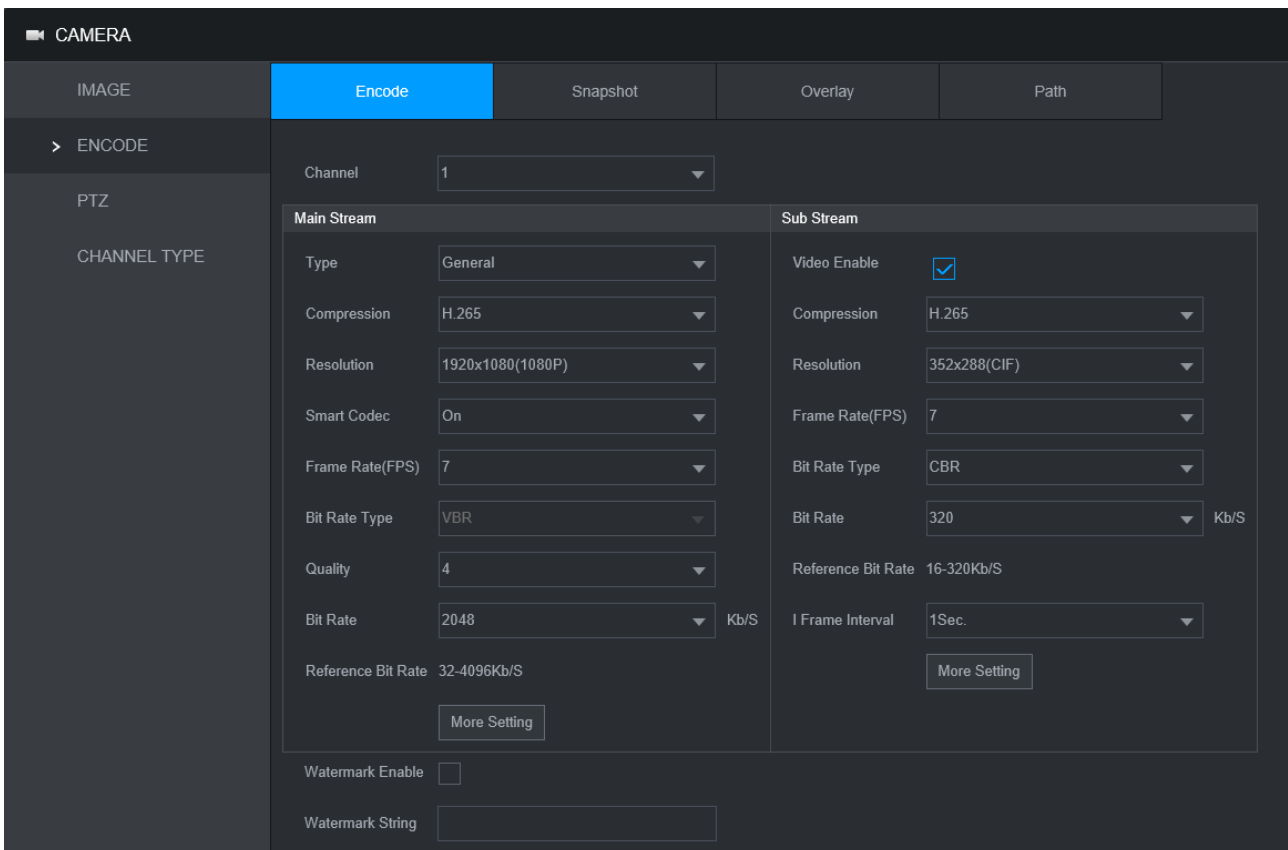

In this menu you can set the compression, resolution frame rate and bitrate etc. for each camera. Note that max. frame rate may be capped differently for certain channels. Resolution should be set

automatically when the camera is detected.

Click Main menu>Camera>Image

In this menu you will have the settings for all of the cameras connected to the DVR.

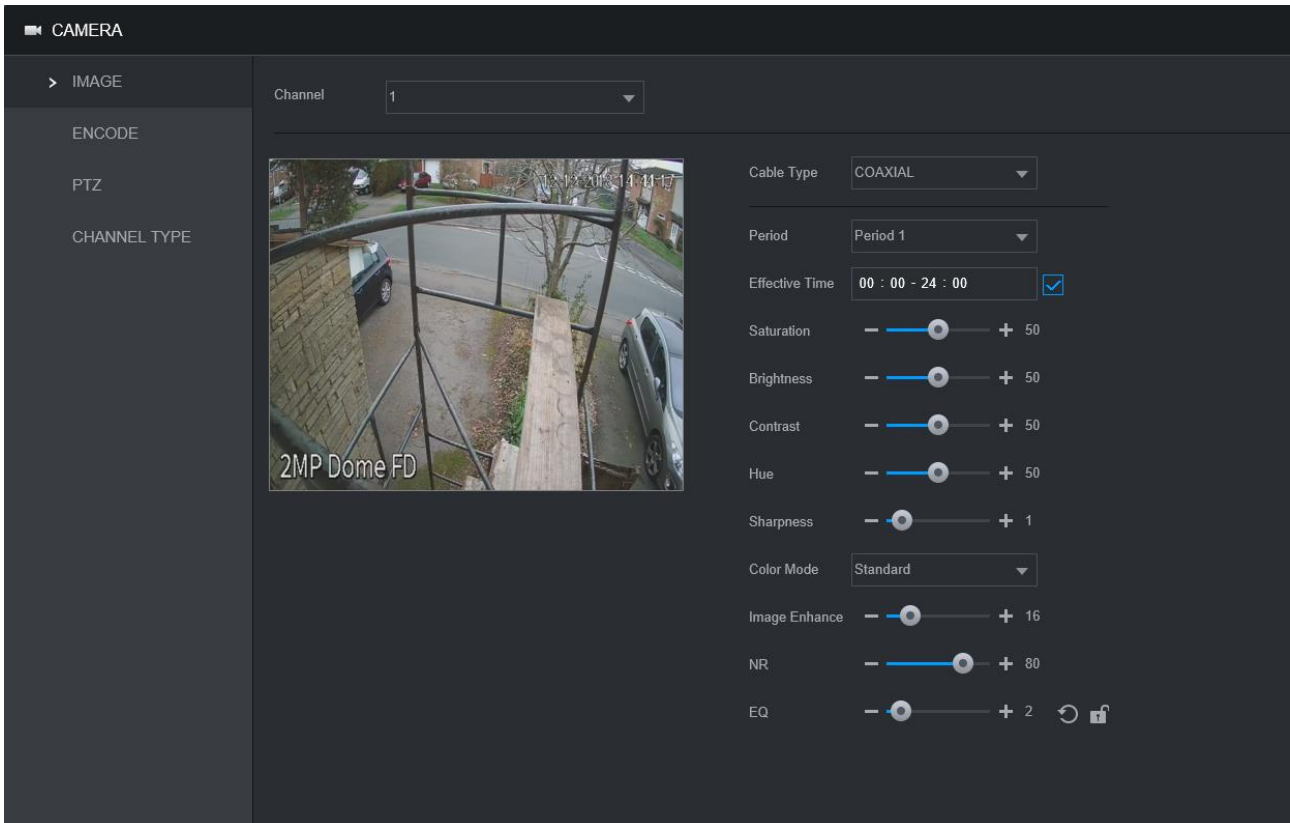

To swap cameras pull down the options in channel. Don't forget to press Apply to save all your changes every time you leave a screen.

Viewing multiple cameras at once

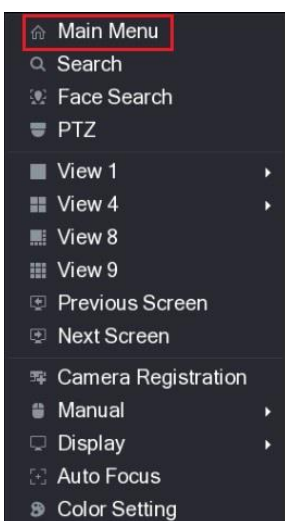

Select view 1 and from there select camera or View 4 to get all camera views onscreen at the same time. In view 4 you need to click into the camera view you want to change to set the camera settings.

To return to the Main menu at any time, left click the screen anywhere that is not on the PZT control or right click and select main menu

Main Menu interface is displayed

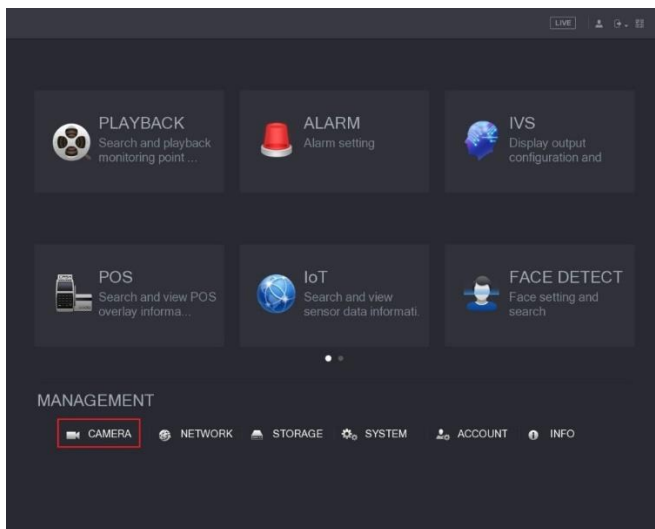

For all other settings refer to the DVR menus and the DVR instructions

4 PIR Local Settings

Your DVR will recognize that a PIR type camera is connected to the system and will enable PIR function automatically. PIR has the advantage of triggering on heat rather than movement and of having limited range. This makes it less prone to false triggering but if you prefer to disable this feature to make use of the additional range that Motion Detect has, do as follows;

- Go to main menu page > select the alarm icon > select the correct channel for your PIR camera and click the Encode PIR box. Tick to enable PIR (default) to no tick to enable motion detection (MD).

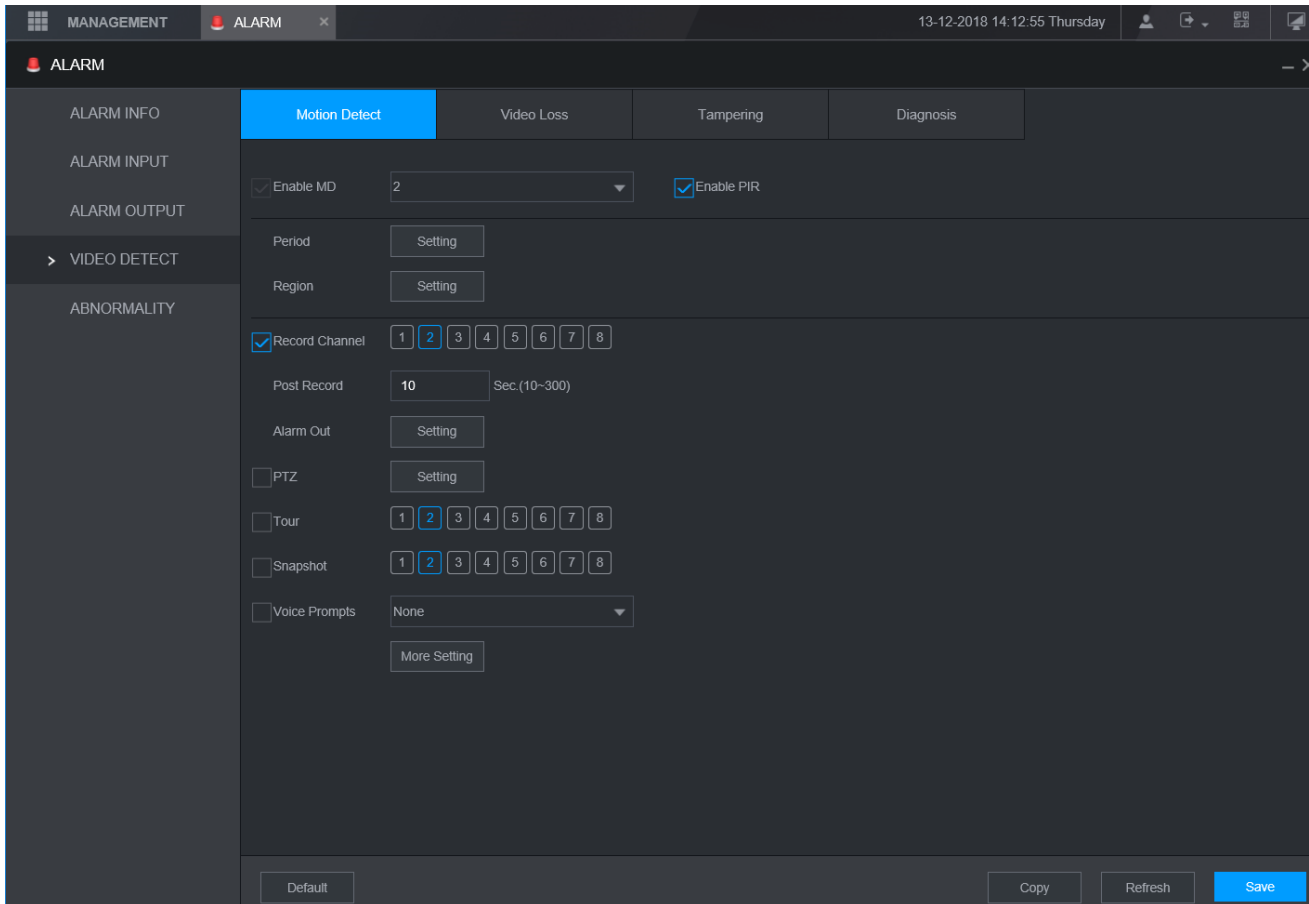

7 Maintenance

Do not disassemble

Camera Body Maintenance

Use a soft dry cloth to clean the camera body when it is dirty. If the dirt is hard to remove, use a clean cloth soaked with mild detergent and wipe gently, and dry immediately with soft cloth. Don't use volatile solvents, strong detergent or abrasives. Such treatment would be considered abuse and would invalidate warranty.

Lens maintenance

The lens cover should be cleaned with water, mild detergent on a soft lint free cloth. Alternatively, materials specifically designed for cleaning optical equipment can be used such as microfibre cloth and lens cleaning solution.

8 Support

If you have any problems with your installation, please first go to the NightWatcher web site to look at the

FAQs. These are updated regularly and are laid out in product families so that they are very specific to your product.

If you can't find the answer you need there contact our call centre by e-mail or phone. See website for details and business hours.

www.nightwatcher.co.uk/support

9 Product Compliance

This device complies with all relevant EU and UK regulations with regards to electrical safety and environmental protection.



Disposal instructions

Despite our best efforts at ecologically sound design and compliance with RoHS regulations, electrical products still contain many materials necessary to their efficient operation that should not be allowed to enter the water table or otherwise pollute the Earth. So, at the end your product's life please dispose of it thoughtfully. Please don't throw it away with unsorted waste, take it to your local recycling centre (Designated Collection Facility) to be recycled as Waste electrical and electronic product. Check with your local authority for addresses and other recycling advice.

10 Specifications

NW-4MP-BP-WH

Camera

Image Sensor 1/3" CMOS

Effective Pixels 2688(H)×1520(V), 4.1MP

Scanning System Progressive

Electronic Shutter Speed PAL: 1/25~1/100000s

NTSC: 1/30~1/100000s

Minimum Illumination 0.03Lux/F2.0(Color), 30IRE, 0Lux IR on

S/N Ratio More than 65dB

IR Distance Up to 20m (66feet)

IR On/Off Control Auto / Manual

IR LEDs 1

Lens

Lens Type Fixed lens / Fixed iris

Mount Type Board-in

Focal Length 2.8mm

Max Aperture F1.8
Angle of View H: 107.2°
Focus Control N/A
Close Focus Distance 1100mm (43.31")

DORI Distance

Note: The DORI distance is a “general proximity” of distance which makes it easy to pinpoint the right camera for your needs. The DORI distance is calculated based on sensor specification and lab test result according to EN 62676-4 which defines the criteria for Detect, Observe, Recognize and Identify respectively.

DORI

Definition Distance

Detect 25px/m

(8px/ft) 2.8mm: 56m(184ft)

Observe 63px/m

(19px/ft) 2.8mm: 22m(72ft)

Recognize 125px/m

(38px/ft) 2.8mm: 11m(36ft)

Identify 250px/m (76px/ft)

2.8mm: 6m(20ft)

Pan / Tilt / Rotation

Pan/Tilt/Rotation

Pan: 0° ~ 360°

Tilt: 0° ~ 90°

Rotation: 0° ~ 360°

Video

Resolution 4MP (2560×1440)

Frame Rate 25/30fps@4MP, 25/30fps@1080P, 25/30fps@720P

Video Output 1-channel BNC HDCVI high definition video output /

CVBS video output (Can switch)

Day/Night Auto (ICR) / Manual

OSD Menu Multi-language

BLC Mode BLC / HLC / DWDR

WDR DWDR

Gain Control AGC

Noise Reduction 2D

White Balance Auto / Manual

Smart IR Auto / Manual

PIR

Detection Passive infrared

Detection Range 10m, 110°

Alarm prompt Red led

Installation height Default bracket, wall mount, 2.2-2.5m

Certifications

Certifications

CE (EN55032, EN55024, EN50130-4)

FCC (CFR 47 FCC Part 15 sub part B, ANSI C63.4-2014)

UL (UL60950-1+CAN/CSA C22.2 No.60950-1)

Interface

Audio Interface N/A

Electrical

Power Supply 12V DC $\pm 30\%$

Power Consumption Max 4.4W (12V DC, IR on)

Environmental

Operating Conditions $-10^{\circ}\text{C} \sim +50^{\circ}\text{C}$ ($+14^{\circ}\text{F} \sim +122^{\circ}\text{F}$) / Less than 95% RH

* Start up should be done at above -10°C (14°F)

Storage Conditions $-10^{\circ}\text{C} \sim +50^{\circ}\text{C}$ ($+14^{\circ}\text{F} \sim +122^{\circ}\text{F}$) / Less than 95% RH

Ingress Protection & Vandal

Resistance IP67

Construction

Casing Aluminium (Front cover) + Plastic (Rear Barrel)

Dimensions 146.6mm \times 72.4mm \times 83mm (5.77" \times 2.85" \times 3.27")

Net Weight 0.23kg (0.51lb)

Gross Weight 0.30kg

NW-8MP-BP-WH

Camera

Image Sensor 1/2" CMOS

Effective Pixels 3840(H) \times 2160(V), 8MP

Scanning System Progressive

Electronic Shutter Speed PAL: 1/4s \sim 1/100,000s

NTSC: 1/3s \sim 1/100,000s

Minimum Illumination 0.005Lux/F1.6, 30IRE, 0Lux IR on

S/N Ratio More than 65dB

IR Distance Up to 20m (66feet)

IR On/Off Control Auto / Manual

IR LEDs 1

Lens

Lens Type Fixed lens / Fixed iris

Mount Type Board-in

Focal Length 2.8mm

Max Aperture F1.6

Angle of View H: 110.8 $^{\circ}$

Focus Control N/A

Close Focus Distance 1800mm (70.87")

DORI Distance

Note: The DORI distance is a “general proximity” of distance which makes it easy to pinpoint the right camera for your needs. The DORI distance is calculated based on sensor specification and lab test result according to EN 62676-4 which defines the criteria for Detect, Observe, Recognize and Identify respectively.

DORI

Definition Distance

Detect 25px/m (8px/ft) 84m(276ft)

Observe 63px/m (19px/ft) 34m(110ft)

Recognize 125px/m (38px/ft) 17m(55ft)

Identify 250ppm (76px/ft) 8m(28ft)

Pan / Tilt / Rotation

Pan/Tilt/Rotation

Pan: 0° ~ 360°

Tilt: 0° ~ 90°

Rotation: 0° ~ 360°

Video

Resolution 8MP (3840x2160)

Frame Rate 15fps@4K, 20fps@6MP, 30fps@4MP

Video Output 1-channel BNC high definition video output / CVBS
video output (DIP switch)

Day/Night Auto (ICR) / Manual

OSD Menu Multi-language

BLC Mode BLC / HLC / WDR

WDR 120dB

Gain Control AGC

Noise Reduction 2D/3D

White Balance Auto / Manual

Smart IR Auto / Manual

PIR

Detection Passive infrared

Detection Range 10m, 110°

Alarm prompt Red led

Installation height Default bracket, wall mount, 2.2-2.5m

Certifications

Certifications

CE (EN55032, EN55024, EN50130-4)

FCC (CFR 47 FCC Part 15 subpartB, ANSI C63.4-2014)

UL (UL60950-1+CAN/CSA C22.2 No.60950-1)

Interface

Audio Interface N/A

Electrical

Power Supply 12V DC \pm 30%

Power Consumption Max 5.3W (12V DC, IR on)

Environmental

Operating Conditions -10°C ~ +50°C (+14°F ~ +122°F) / Less than 95% RH

* Start up should be done at above -10°C (14°F)

Storage Conditions -10°C ~ +50°C (+14°F ~ +122°F) / Less than 95% RH

Ingress Protection & Vandal

Resistance IP67

Construction

Casing Aluminium (Front cover) + Plastic (Rear Barrel)

Dimensions 146.6mm×72.4mm×83mm (5.77"×2.85"×3.27")

Net Weight 0.25kg (0.55lb)

Gross Weight 0.33kg (0.73lb)